

# WINSLOW ADAPTICs

## Data Sheet – Shrink Screw Machined I.C. Sockets W30564/7TRC W30564/7T

The W30564/7 Series uses a screw machined half hard brass outer pin with a beryllium copper contact. The outer pin has 2 plating options; RoHS compliant Tin and Tin/Lead. The beryllium copper contact is Gold.

Moulding material is 30%GF PBT rated to UL 94 V-0. Part are designed and packaged for automatic PCB loading machines. The following table explains the plating options for the range.

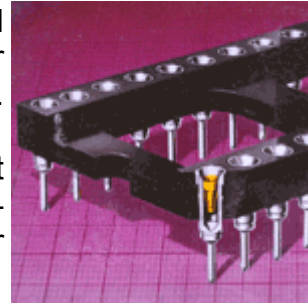

SUFFIX	OUTER PLATING	CONTACT PLATING
TRC	Pure Tin (RoHS Compliant)	Gold
T	Tin Lead	Gold

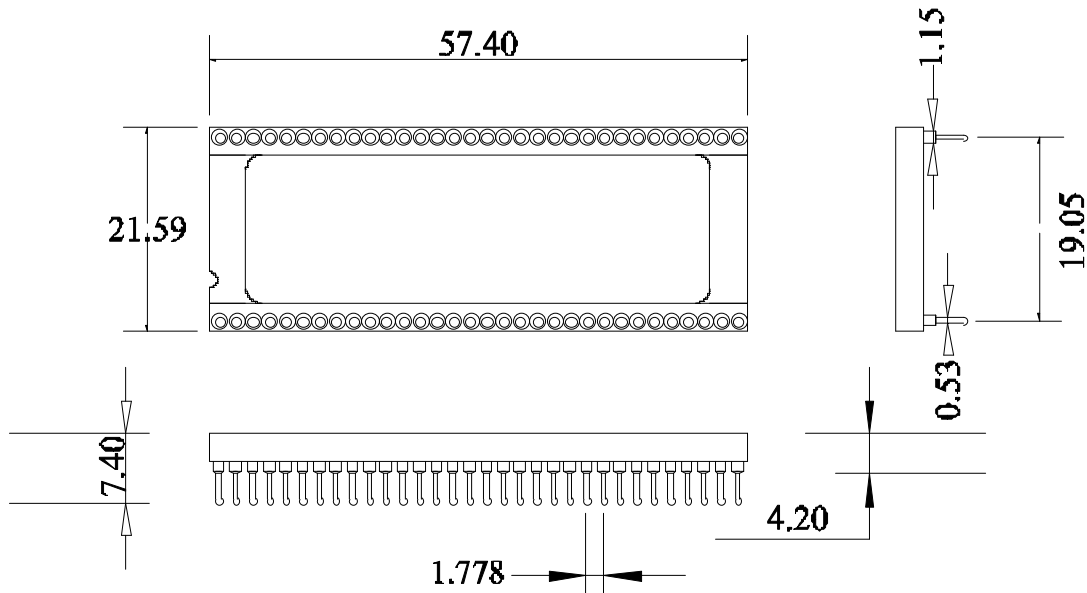

# WINSLOW ADAPTICs

## Data Sheet – Shrink Screw Machined I.C. Sockets W30564/7TRC W30564/7T

### General Specifications. Unless stated all values are typical.

#### Contact

Resistance:	10 mOhms	Current Rating:	5.0 amps
Capacitance:	1pF max	Material:	Brass outer, beryllium copper inner.
*Plating: Outer;	W30564/7TRC	Nickel 2.5Um/Pure Tin 6.0Um	
	W30564/7T	60/40 tin/lead 2-3Um.	
*Plating: Inner;	W30564/7TRC	Nickel 2.5Um/Gold 0.1Um	
	W30564/7T	Nickel 2.5Um/Gold 0.1Um	

Note: Other plating specs available.

Please contact [sales@winslowadaptics.com](mailto:sales@winslowadaptics.com) with your requirements.

Insertion Force:	2 N per pin 0.43mm diameter
Withdrawal Force:	1 N per pin 0.43mm diameter.
Force to remove from moulding:	9lb minimum
Pluggable Depth of I.C. leg from top of socket:	3.6mm
Depth from top of socket to contact point:	2.4mm

#### Moulding

Material:	Glass-reinforced Polyester (PBT)
Insulation Resistance:	1010 Ohms (contact to contact) at 500VDC
Arc Resistance:	145 seconds at 23 degrees C
Electrical Strength:	121KV/cm at 23 degrees C
Dielectric Constant:	3.9 (48 hrs 90%RH) at 100Hz 23 degrees C 4.5 at 100Hz 121 degrees C 3.7 (48 hrs 90%RH) at 1MHz 23 degrees C 4.3 at 1MHz 121 degrees C
Dissipation Factor:	0.0077 (48 hrs 30%RH) at 100Hz 23 degrees C 0.0300 at 100Hz 121 degrees C 0.0150 (48 hrs 30%RH) at 1MHz 23 degrees C 0.0200 at 1MHz 121 degrees C
Volume Resistivity:	3 x 10 <sup>13</sup> ohms-CM (48 hrs 90%RH) at 25 degrees C 10 <sup>13</sup> ohms-CM at 121 degrees C
Operating Temperature:	-65 to 150 degrees C
Flammability:	UL94V-0

[sales@winslowadaptics.com](mailto:sales@winslowadaptics.com)

DIP Support products from Winslow Adaptics

[www.winslowadaptics.com](http://www.winslowadaptics.com)



Custom Upgrades

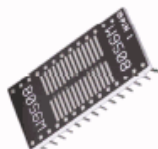

Package

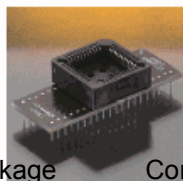

Conversion

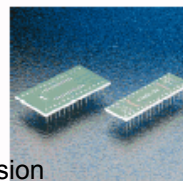

Pitch Change

Also available from Winslow Adaptics are cost effective, time saving solutions to test, obsolescence, supply problems and upgrades. OEMs can upgrade equipment with custom Adaptics utilising additional logic, often saving considerable cost and time on re-design. If lead-time becomes an issue contact us for a suitable package convertor. We specialise in conversion of all package lead-frames.